

ASTROSDR

ASTROSDR

SDR AND DSP SYSTEM FOR SPACEFLIGHT

- Dual receivers & transmitters, 70 MHz to 6 GHz
- Xilinx Zynq Z-7045 FPGA & dual ARM system-on-chip (SoC)
- Daughter card interface for expansion, I/O, and custom applications
 - 64 Gbyte eMMC flash memory card
 - Gigabit Ethernet and flash memory card with GPIO
- 64 GByte eMMC flash on daughter card for data storage
- Designed for CubeSat Next-Generation Bus (CNGB) and Space Plug-and-Play Architecture (SPA)

THE ASTROSDR PRODUCT FAMILY provides key components for a user-developed RF payload: receiver, transmitter, FPGA, ARM processor, data storage, and high-speed I/O. The board-support-package includes pre-build functions for interfacing to the radio, ARM processor, and eMMC storage, as well as a Vivado project to assist the user in developing their own unique applications.

ASTROSDR HAS THE DEVELOPER-FRIENDLY FEATURES found in our terrestrial SDR and DSP systems. The on-board processor runs embedded Linux, providing a flexible and capable development environment. APIs are provided for basic control of the FPGA, receivers, and transmitters.

ASTROSDR HAS MULTIPLE INTERFACES for I/O and command/control: dual UARTs, two FPGA-attached LVDS pairs, and an Ethernet interface on an optional daughter-card.

RINCON RESEARCH SUPPORTS MISSIONS with more than just hardware. We provide mission planning and operation services. We also have unique IP for digital signal processing, including interference cancellation, high-rate modems, adaptive beamforming, geolocation, and space situational awareness.

BLOCK DIAGRAM

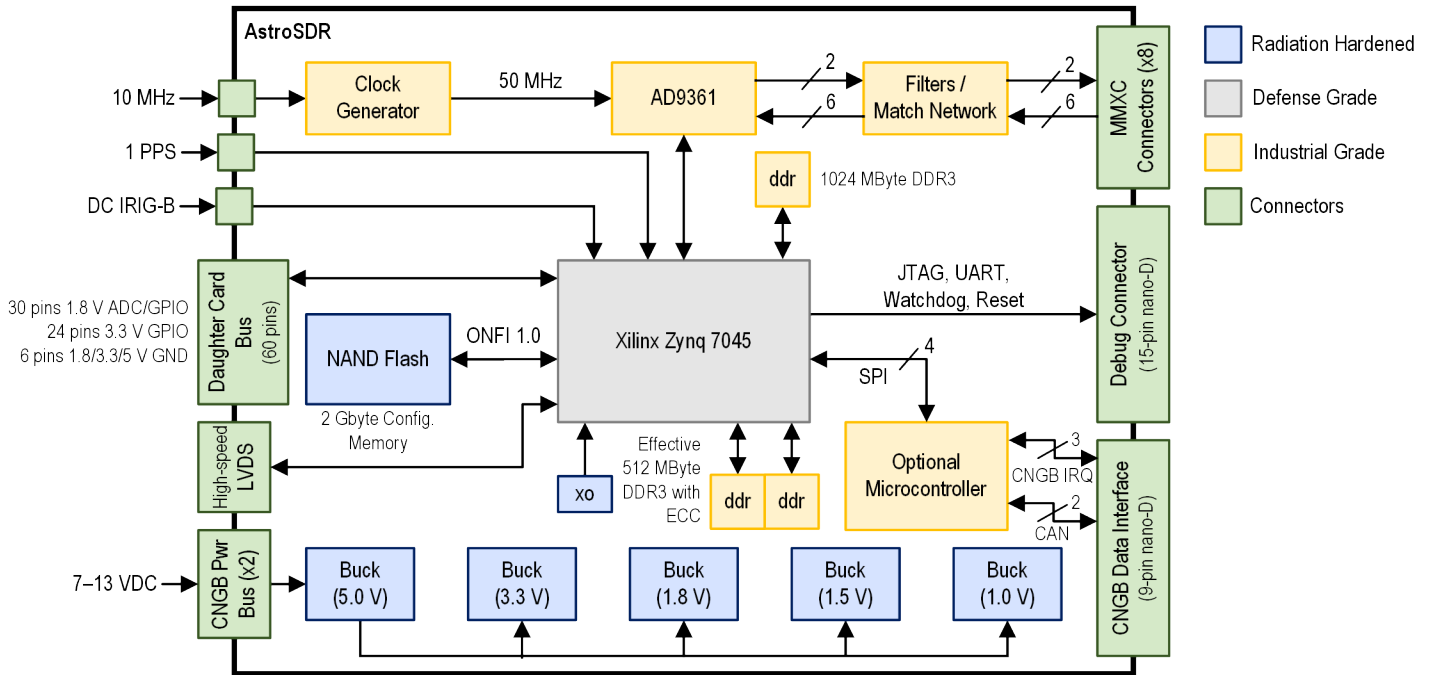

SPECIFICATIONS

PROCESSING

- Xilinx Zynq 7045 FPGA and dual ARM SoC
- Dual-core Arm Cortex A9 with NEON, up to 733 MHz
- 512 MByte DDR3 RAM (with ECC)
- 2 GByte flash for radiation-tolerant OS storage
- Kintex-7 FPGA fabric: 350k logic cells
- 900 DSP slices
- 1 GByte DDR3 RAM (ECC capable)
- 64 GByte eMMC flash on daughter card, designed to support dual-channel recording at up to 8 MS/s (32 Mbytes/s)
 - Each eMMC supports sustained write speeds of 8Ms/s

MECHANICAL

- 90 mm x 90 mm (3.543" x 3.543")
- Approximately 95 grams (without heatsink or daughter card)

ENVIRONMENT

- Operating Temp: -40°C to 85°C (flight), 0°C to 85°C (eng.) wider range available upon request
- Vibration: Passed GEVS proto-qualification levels
- Thermal Vacuum: Passed CNGB spec -20°C to +50°C operational
- Projected radiation performance report available upon request

POWER

- Power: CNGB compliant, 7 VDC to 13 VDC
- Standby: 18 mW (typ)
- System Management: 3.5 W (no FPGA load, ARM booted)
- Idle: 4 W (typ)
- Passive Collect: 5.5 W (typ, includes recording to flash)
- Max: 30 W

DIGITAL INTERFACES

- **CAN:** Microcontroller connected and bus powered
 - Remote on/off capable
 - 9-pin nano-D connector (2x for pass-through)
- **Timing Signals:** FPGA connected
 - 1 PPS, 5/10/50 MHz reference
 - Serial timecode (DC-IRIG-B) (MMCX)
- **Daughter Card Interface:** 30 pins 1.8 V GPIO (includes 11 ADC channels)
 - 24 pins 3.3 V GPIO
 - Samtec LSHM-130 60-pin strip, available for connections to custom board or cables
- **LVDS:** FPGA connected, 4-LVDS pairs up to 200 MHz operation (or 8 GPIO)
 - 9-pin nano-D connector
 - Supports HDLC (transmit only)
 - Supports SpaceWire link layer
- **Development Interface:** External watch dog timer input, Reset, JTAG, UART console
 - 15-pin nano-D connector

ECCN 9A515

ADDRESS
101 N. Wilmot Rd., Ste. 101
Tucson, AZ 85711

ORDER LINE
520.519.3131
sales@rincon.com

TECH SUPPORT
520.519.3132
tech-line@rincon.com

FAX/WEB
520.519.3120
www.rincon.com

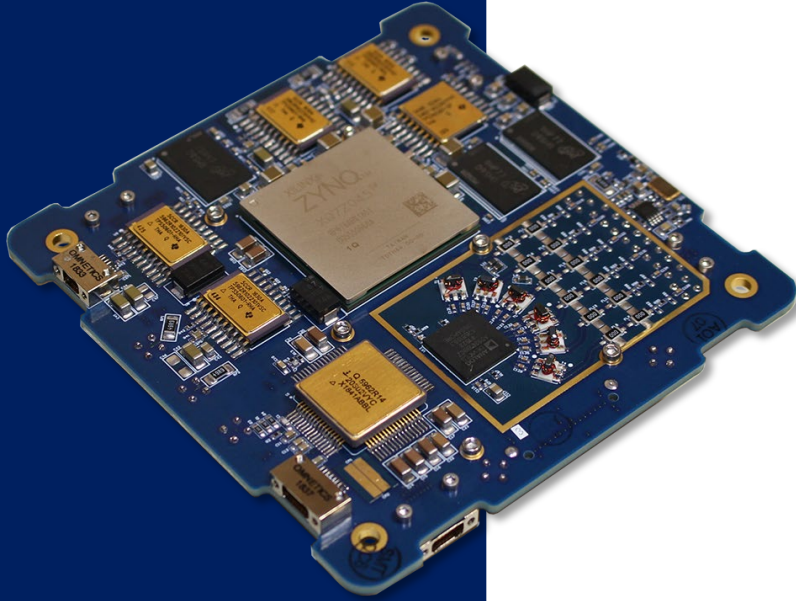

ASTROSDR

ASTROSDR SDR AND DSP SYSTEM OPTIONS

SPECIFICATIONS

COMMERCIAL-GRADE BASE CARD

- Operating Temperature: 0°C to 85°C
- PCB Fab Spec: IPC 2
- Solder Type: Tin-Lead
- FPGA/Processor: Extended Temperature Range, lidless package, Speed Grade 2
- DC to DC Voltage Converter ICs: Industrial Temperature Range, Commercial Grade
- Configuration Memory: 1 GByte, Industrial Temperature Range, Commercial Grade
- Primary Oscillator: Industrial Temperature Range, Commercial Grade
- Light-Emitting Diodes (LEDs): Installed to indicate power supply status and FPGA program status
- Suggested Use: Flatsat operation, application development, system integration and test

FLIGHT-GRADE BASE CARD

- Operating Temperature: -40°C to 85°C
- PCB Fab Spec: IPC 3A
- Solder Type: Tin-Lead
- FPGA/Processor: Defense (Q) Grade, with heat spreader, Speed Grade 1
- DC to DC Voltage Converter ICs: S-Class Qualified with Supporting Documentation, Flight Grade
- Configuration Memory: 2 GBytes, S-Class Qualified with Supporting Documentation, Flight Grade
- Primary Oscillator: S-Class Qualified with Supporting Documentation, Flight Grade
- Light-Emitting Diodes (LEDs): No LEDs installed
- Suggested Use: Space flight, environmental qualification testing

AGILE RF SUBSYSTEM

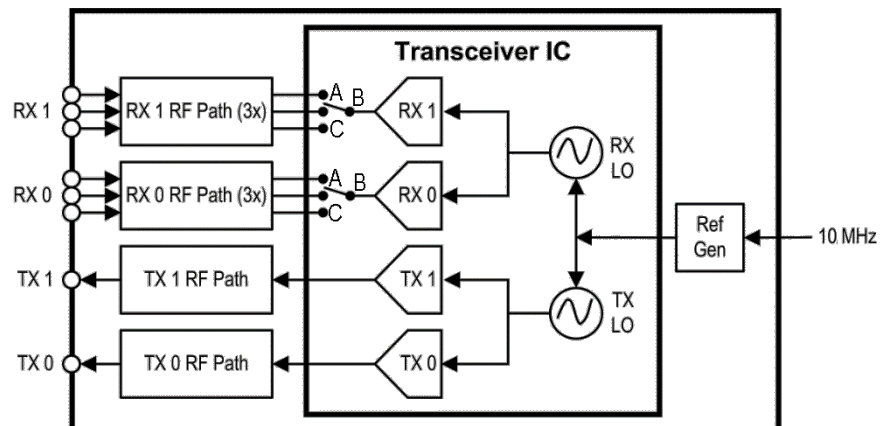

RX RF PATH DETAIL

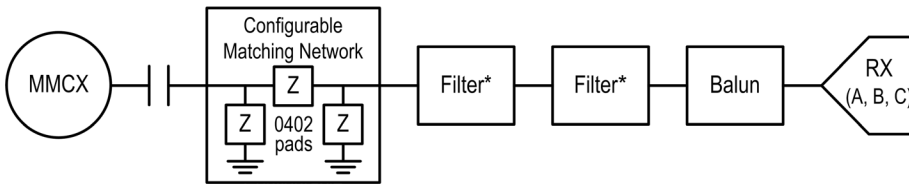

TX RF PATH DETAIL

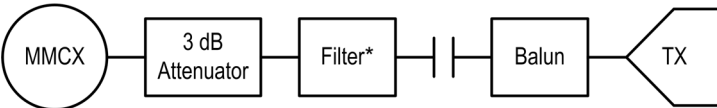

*Filter sites support LPF, HPF, or BPF in Mini-Circuits FV1206, FV1206-4, and JV1210C packages.

GIGABIT ETHERNET AND FLASH MEMORY DAUGHTER CARD

- RRC PN: ASDR-DC-GE32G-01
- Storage:
 - 32 GByte (1 x 32 GB) eMMC flash on daughter card, designed to support up to 32 MB/s
 - MicroSD Card Cage
- Ethernet Connector: Omnetics single row 9 pin
- GPIO Connector: Omnetics dual row 9 pin: 7 bits 1.8V GPIO, 1.8 VDC, and GND
- Physical Layer Transceiver:
 - Microchip VSC8501XML-03
 - 10/100/1000BASE-T
 - RGMII Mac interface, EMIO

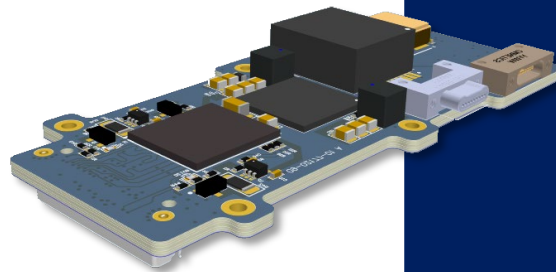

FLASH MEMORY DAUGHTER CARD

- RRC PN: ASDR-DC-64G-01
- Storage:
 - Supports dual-stream recording at up to 32 MB/s each
 - Can alternatively run in snapshot mode, recording a burst of 512 MB of data at up to 61.44 MS/s
 - MicroSD Card Cage

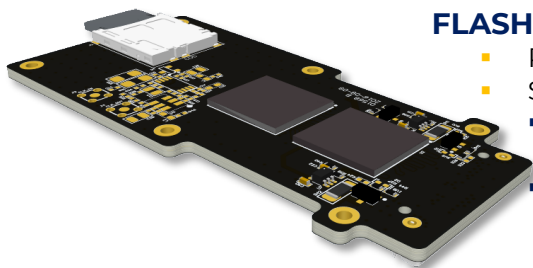

RF

- **Tuning Range:**
 - 70 MHz to 6 GHz
 - Dual RX (single RX LO)
 - 3 input paths per RX
 - Dual TX (single TX LO)
 - 1 path per TX
 - Locations for SMT filters and matching networks on all RF paths
- **ADC/DAC Resolution:** 12 bit
- **Max Bandwidth:**
 - 56 MHz single, 25 MHz dual
 - (61.44 MSPS, 30.72 MSPS)

TIMING

- **5/10/50 MHz:**
 - 0.1 Vpp to 3.3 Vpp
 - 16 dBm to 14 dBm
 - 50 Ohm
 - Sine wave or square wave
- **IRIG-B-DC:**
 - 2.0 V to 5.0 V
 - 50 Ohm
- **1 PPS:**
 - 2.0 V to 5.0 V
 - 50 Ohm

ADDRESS

101 N. Wilmot Rd., Ste. 101
Tucson, AZ 85711

ORDER LINE

520.519.3131
sales@rincon.com

TECH SUPPORT

520.519.3132
tech-line@rincon.com

FAX/WEB

520.519.3120
www.rincon.com

RINCON
RESEARCH
EMPLOYEE OWNED